

**KALVIS**<sup>®</sup>

**CENTRAL HEATING  
SOLID FUEL BOILER**

**KALVIS - 2 - 30 U**

**KALVIS - 2 - 40 U**



**TECHNICAL CERTIFICATE, INSTALLATION AND  
MAINTENANCE MANUAL**



IST 144948958.13.2011 LST EN 303-5  
ГОСТ 20548-87 ГОСТ 20548-93

Pagaminta Lietuvoje

Stick product  
barcode here

F-02/IN- F-02/IN-04

To \_\_\_\_\_

**Application for Warrant Service**

After having familiarized with boiler “**Kalvis**\_\_\_\_\_” certificate (product No. \_\_\_\_\_) and, in accordance with the requirements set forth therein, having connected the boiler to heating system and chimney, I have the following claims:

I. \_\_\_\_\_

Thinking that this happened due to defects of the boiler, I ask you to send your representatives for checking the installed boiler, finding and elimination of the defects found.

If the mentioned boiler faults occurred due to incorrect connection of operation of the boiler, I oblige myself to indemnify the arrival costs of your representatives ( \_\_\_\_\_) and time spend during the trip and in situ ( \_\_\_\_\_ per employer including driver).

My address \_\_\_\_\_ tel. \_\_\_\_\_

\_\_\_\_\_  
Name Surname

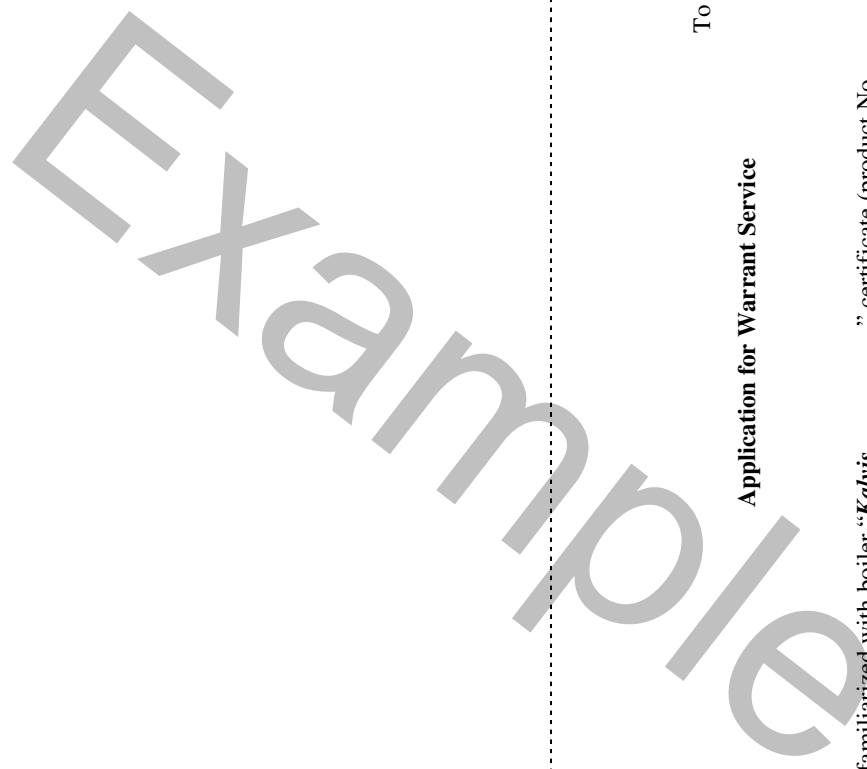



**REPORT ON BOILER INSTALLATION**

**DEAR BUYER**

*We are very pleased that you have purchased our manufactured central heating boiler. This versatile product is designed for space heating. For combustion you can use a variety of solid lump well dried fuel. If desired, the boiler is easy to adapt for stoking in mechanized way, with pellets. The boiler is manufactured using modern materials and technologies.*

*We believe that if you carefully read this guide, properly install and operate the boiler, it will cause no troubles in handling, and serve you reliably, safely for a long time.*

*We wish you a warm and comfortable life!*

**Boiler was installed by:**

Company: \_\_\_\_\_

Address: \_\_\_\_\_ City: \_\_\_\_\_

Telephone, fax, e-mail: \_\_\_\_\_

**Data:**

**Chimney:**

**Flue pipe:**

Dimensions: \_\_\_\_\_ Diameter: \_\_\_\_\_

Height: \_\_\_\_\_ Length: \_\_\_\_\_

Chimney draught: \_\_\_\_\_ Number of elbows: \_\_\_\_\_

Last revision date: \_\_\_\_\_ Outgoing smoke temperature: \_\_\_\_\_

**Brief description of boiler connection:** \_\_\_\_\_

\_\_\_\_\_  
\_\_\_\_\_  
\_\_\_\_\_  
\_\_\_\_\_

**Fuel used for testing:**

Type: \_\_\_\_\_ During boiler testing functions of all boiler,

Size: \_\_\_\_\_ regulation and safety elements were checked

Moisture: \_\_\_\_\_

Person responsible for installation (and testing) : \_\_\_\_\_

Date: \_\_\_\_\_ Customer's signature: \_\_\_\_\_

## SALES MARK

### **Boiler was sold by:**

Company: \_\_\_\_\_

Sales date: \_\_\_\_\_

Address: \_\_\_\_\_

Telephone: \_\_\_\_\_

### **In the case of failure please call:**

Company: \_\_\_\_\_

Address: \_\_\_\_\_

Telephone: \_\_\_\_\_

## 1. Recommendations

***In order the boiler served long and without troubles and you did not loose the right for guarantee service, please observe the following main rules:***

1. *Boiler installation, adjustment, operator training can be performed by a firm, attested for such jobs and having qualified specialists or by representative authorized by manufacturer. **Installation note has to be done in this certificate, installation report.***
2. *Boiler has to be installed in accordance with recommended or other diagrams, with 4-way mixing valve or thermostatic 3-way valve in order, to ensure temperature that the water returning to the boiler was of no lower than 60°C.*

**Attention: If you fail to meet this requirement, corrosion will occur due to condensate which will significantly reduce service life of the body and ceramic tiles.**

3. *Optimum operation of the boiler is achieved at close to nominal power.*
4. *If boiler power is too high and it has to be operated at lower than nominal power, we recommend to install the boiler with accumulation capacity.*
5. *Use fuel no damper than 25%. In the case of higher fuel dampness, boiler power drops, fuel consumption rises.*

**Note.** *This operation manual is compiled following the requirements provided for in LST EN 12171 Building Heating Systems. Operation, Maintenance and Use Document Preparation Procedures. Heating Systems Needing no Trained Operator.*

## 2. Purpose

Solid fuel water heating boiler *Kalvis 2-30U*, *Kalvis 2-40U* (hereinafter referred to as boiler) is designed for heating of various premises where central heating system is installed with natural or forced circulation and closed or open expansion system. The boiler operates most efficiently under nominal taken thermal power, if operating with lower power, accumulation capacity is recommended to use.

## 3. Main Technical Specifications

Boiler model		<i>Kalvis-2-30U</i>	<i>Kalvis-2-40U</i>
Nominal power (Q <sub>N</sub> ), kW *		30	40
Minimum power (Q <sub>min</sub> ), kW *		8	15
Heated area, m <sup>2</sup> , when building partition thermal resistance is ~ 2,5 m <sup>2</sup> ·K/W		220 ... 380	300 ... 480
Fuel consumed *		firewood ****	
Size of firewood L x Ø, up to, cm		35 x 15	45 x 15
Position of firewood in hearth		across or along	across
Loading hole sizes, mm:	from top	288 x 492	288 x 592
	from bottom	230 x 292	230 x 292
Hearth volume, dm <sup>3</sup> (l)		160	200
Fuel * combustion time (Q <sub>N</sub> ), hrs.		4 ... 5	
Approx q-ty of consumed firewood per season, Q <sub>N</sub> / Q <sub>min</sub> , m <sup>3</sup> *		18 ... 28	25 ... 35
Efficiency rate during operation at nominal power, no less than, %		82	
Boiler class under LST EN 303-5		2	
Boiler water capacity, l		102	116
Min volume of accumulation capacity, l *		800	960
Water pressure in boiler no more than, MPa (kgf/cm <sup>2</sup> )		0,15 (1,5)	
Max permissible water temperature, °C		95	
Min return water temperature during operation, °C		57	
Hydraulic resistance, mbar		8	8,3
Operation environment temperature, °C		3 ... 60	
Temperature regulator adjustment range, °C		65 ... 90	
Parameters of cold water used for excess heat dissipation: ** (***)	pressure, bar	≥ 2,0 **	
	temperature, °C	≤ 15 **	
Min chimney draught, Pa		26	35
Adjustable exhauster node type ***		DM-01	
Adjustable cooling coil type ***		AAG9	
Exhausted flue temperature, up to (Q <sub>N</sub> / Q <sub>min</sub> ):, °C		200 / 90	200 / 90
Exhausted gas volume at Q <sub>N</sub> , kg/s (m <sup>3</sup> /val)		0,025 (113)	0,035 (158)
Exhausted gas volume at Q <sub>min</sub> , kg/s (m <sup>3</sup> /val)		0,013 (59)	0,016 (72)
Connection flange sizes:	to exhauster (K), mm	Ø178	
	to system (M), G	G2-B	
	for output (N), G	G½-B	
Sizes, no more than (Overall / at transportation on pallet)	height, mm	1540 / 1700	1540 / 1700
	width, mm	715 / 800	815 / 900
	length, mm	1260 / 1300	1260 / 1300
Mass, no more than (net/gross), kg		364 / 385	473 / 494

\* Firing with 18-20 % damp birch firewood.

It is not recommended to fire with firewood damper than 30%.

\*\* For boilers with emergency cooling system installed.

\*\*\* Available for installation having purchased separately.

\*\*\*\* As spare fuel, coal, lump wood waste, chip or peat briquettes can be used.

## 14. Product warranty and guarantee service conditions

Manufacturer guarantees that product is in line with technical documentation requirements.

• *If you correctly install and operate the boiler in accordance with these instructions, the following guarantee service period will be applied calculated from the purchase date:*

- for boiler case - 24 months.
- for completing parts - 12 months.
- for wearing parts - 6 months.

• *Please take care for the installation works performing person or firm filled the installation report.*

• *Manufacturer obliges to eliminate failures occurring due to its fault during the mentioned period for free.*

• *Manufacturer takes no obligation for boiler operation and related consequences, grants no warrant if the boiler is inadequately selected, poorly installed (see chapter 6) or operated (see chapter 7) and this is found out during the visit at user. In this case user shall pay for technicians' arrival and repairs!*

• *No rarely than once a year perform revision of the boiler and its control elements with the help of adequately qualify specialists.*

• *Keep purchase receipt or invoice throughout the warrant period.*

• *For warrant repairs apply to this service providing company, specified by seller.*

• *In the case of boiler failure, apply to the specified service, upon its arrival fill the application form shown on the last page.*

• *We ask user to take care for after warrant repairs service employee made relevant record in this certificate "Notes about warrant and non-warrant repairs" and filled warrant repairs report*

*I familiarized with warrant repairs conditions. I am informed that in the case boiler is installed and operated without observing the requirements given in this manual otherwise I loose the right for warrant repairs.*

Buyer: \_\_\_\_\_  
(name, surname, signature)

### 12. Set

- |  |         |
|--|---------|
| 1. Boiler "Kalvis-2-__U"                   | - 1 pc. |
| 2. Draught regulator (screwed into boiler) | - 1 pc. |
| 3. Scraper                                 | - 1 pc. |
| 4. Ash removal scoop                       | - 1 pc. |
| 5. Poker                                   | - 1 pc. |
| 6. Ash pick                                | - 1 pc. |
| 6. Technical certificate of boiler         | - 1 pc. |
| 7. Wooden pallet for transportation        | - 1 pc. |

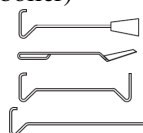

Electric heating block, cooling coil with temperature valve and exhauster node are not included into the boiler set.

### 13. Acceptance certificate.

Solid fuel heating boiler "Kalvis-2-\_\_U" plant No. \_\_\_\_\_ meets drawings, *IST144948958.13.2011*, *LST EN 303-5*, *ГОСТ 20548-87* and *ГОСТ 20548-93* standard requirements and is fit for use.

Boiler was tested with 0,4 MPa pressure.

Manufacturing date \_\_\_\_\_

Supervisor \_\_\_\_\_

**Manufacturer**

**UAB "Kalvis"**  
**Pramonės 15, LT-78137 Šiauliai, Lithuania**  
**Telephone: (370 41) 540556, 540558, 540565**  
**E-mail: prekyba@kalvis.lt**

### 4. Construction description

**Note:** Since boiler construction is under constant improvement, non-essential deviations from this manual are possible.

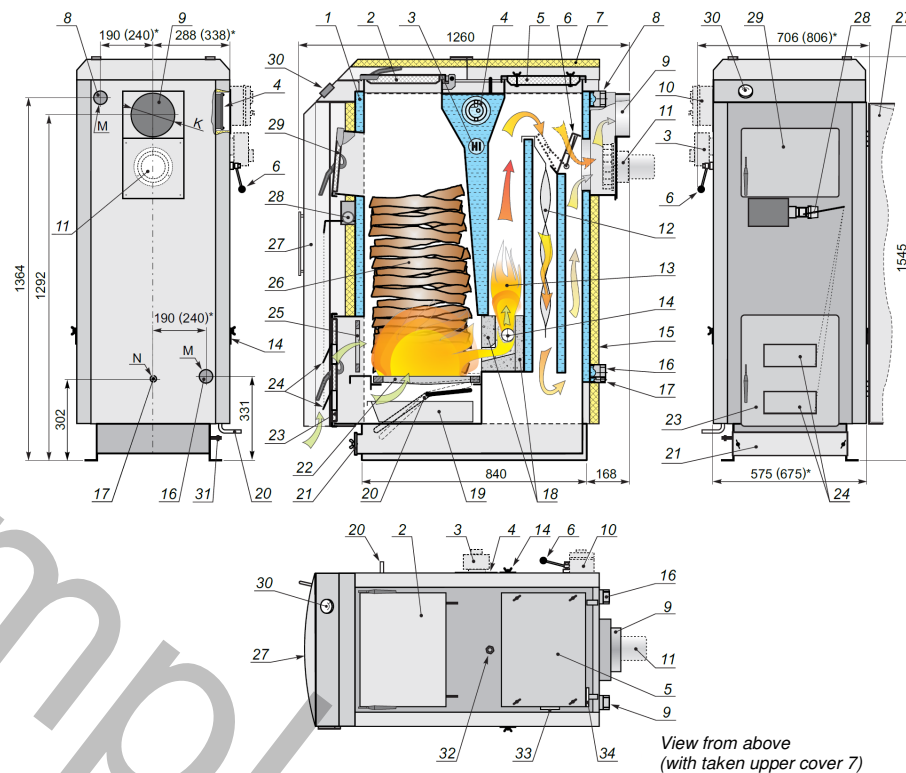

Fig. 1.

1. Boiler body. 2. Upper loading cover. 3. Electric heating element installation place \*\*. 4. Cooling coil installation place \*\*. 5. Service cover. 6. Firing valve. 7. Upper decorative cover. 8. Hot water branch. 9. Flue pipe. 10. Exhauster control panel installation place \*\*. 11. Exhauster installation place \*\*. 12. Turbulizers. 13. Secondary combustion chamber. 14. Secondary air holes with valves. 15. Decorative thermal insulation shields. 16. Return water branch. 17. Outlet branch. 18. Catalyser combustion chamber tiles. 19. Ash drawer. 20. Firegrate lifting gear. 21. Sooth removal cover. 22. Movable firegrate. 23. Hearth door. 24. Primary air supply valves. 25. Cast iron door. 26. Hearth. 27. Front decorative door. 28. Draught regulator. 29. Fuel loading door. 30. Thermal pressure gauge\*\*\*. 31. Grounding screw. 32. Boiler lifting screw for transportation. 33. Thermal pressure gauge sensor socket. 34. Emergency thermostat sensor socket.

\* Overall sizes specified for „Kalvis-2-30U (Kalvis-2-40U)“

\*\* Available for installation having purchased separately.

\*\*\* Thermal pressure gauge installed on the boiler (0-120°C, 0-4 bar) is of indication-type and does not replace obligatory heating system devices.

Boiler body (1) (see fig. 1), welded from steel sheets has water spaces where water is heated. Body's internal part walls are 6 mm thick, external part 3 mm thick. Body is covered with decorative shields with heat insulation (15). Front part is closed with decorative door (27).

In the front part of the boiler there is thermal pressure gauge (30); fuel loading chamber door (29); draught regulator (28) controlling primary air supply valves (24); hearth door (23), behind it there is cast iron door (25); soot removal cover (21).

Inside the body there is firing valve installed (6), opening the way for flue to get directly to the chimney, used during boiler firing or additionally loading fuel. Air necessary for combustion, is supplied through firegrate (22) and secondary air holes (14). From the bottom there is fuel loading chamber cover (2) and, under the closable decorative shield (7) there is service cover (5) for cleaning of inner surfaces of the boiler.

In the sides of the boiler there are secondary air regulation valves (14).

In the rear part of the boiler there is water discharge branch (17), returning cooled (16) and discharged hot (8) water branches, flue pipe (9).

In the rear wall below flue pipe (9), closed with cover, there is the place to fasten separately purchase exhauster node **DM-01** (11).

In the side wall of the boiler, under decorative coating, there is branch welded (4) used for installation of boiler cooling coil.

In the boiler's heat exchanger there are turbulizers suspended (12) which improve heat take-away. If chimney draught is insufficient, turbulizers are recommended to remove.

In the lower part of secondary combustion chamber (13) there are heat-proof concrete bricks (18) installed, which maintain high temperature in the chamber, assure full combustion of flue gas, which results in reduced volumes of harmful pollutants emission into atmosphere.

Into the boiler, having unscrewed heating element socket cover (4), it is possible to install separately purchased 3x1,5...3x2 kW electric heating elements (with 2" thread) with temperature regulation and emergency thermostats or without them.

**It is prohibited to change boiler construction without permission.**

## 5. Transportation and storage

Boilers are stored and transported fastened onto wooden pallet and twisted with polythene film, of nothing else is agreed in the supply agreement (see fig. 2a.).

Boilers are allowed to transport exclusively in vertical position with any kind of covered transport. If weather is dry, open transport is allowed. Extra measures have to be taken to protect boilers from falling down, scratching against each other. During loading/unloading/transportation it is prohibited to beat, turn, throw the boilers.

### The following is necessary:

- Periodically (twice a year) check if grounding is working properly;
- Before cleaning the boiler disconnect it from electric power network.

## 10. Wearing parts in boiler use

Sealing parts from glass fibre; cast iron firegrate (21) (see fig. 1) and doors (24); heat-proof concrete parts (18) (see fig. 1 and 5) can become worn, burn out, disintegrate while in use.

These parts are available for purchase at boiler manufacturer or its agents.

**Note.** It is advisable to use only manufacturer's original spare parts.

## 11. Fuel types and properties

Combustion heat of absolutely dry wood actually doesn't depend on wood spice and is equal about 4500 kcal/kg. So, as to assess different wood species, one should take into consideration their comparative weight. Weight per cubic metre of various firewood species is as follows:

- oak firewood - 500 kg;
- birch firewood - 450 kg;
- fir firewood - 330 kg;
- aspen firewood - 330 kg.

The damper is firewood the less is its caloric content. Wet firewood calorificity reduction, compared with dry firewood (dampness ~20 %) is as follows:

- 30 % moisture - 10 ÷ 15 %;
- 50 % moisture - 35 ÷ 40 %.

Just cut tree contains 35 ÷ 60 % water. Tree cut in the beginning of winter contains least quantity of water. Hardwood contains less water.

Wood has to be cut and split to make firewood. Firewood, after one year spent in garret is of 20 ÷ 25 % moisture.

After two years it is 13 ÷ 17 %, and this means that after drying less fuel is needed than combustion with damp firewood.

Equal weight of firewood and peat give similar heat quantity.

1 kg of coal gives 2 ÷ 3 times more heat than 1 kg of firewood, due to this reason, coal change into hearth should not exceed 10 kg.

Volume of air needed to combust 1 kg of firewood is 4 ÷ 5 m<sup>3</sup>, for coal - 10 m<sup>3</sup>.

The poorer quality is fuel, the more ash it generates.

Combustion of 1 kg average calorificity coal gives about 6500 kcal (7,56 kWh).



Fault	Reasons	What to do
Boiler does not reach nominal power	Bad, damp fuel. Poor draught.	Use drier fuel, opening firing valve. Check chimney draught.
Boiler weeps	Bad fuel. Too low return water temperature (>57°C !). Poor draught.	Check boiler primary air valve adjustment with draught regulator. Use dry fuel. Adjust mixing valve and circulation pump switch on time according to temperature (if thermostatic power switch is installed).
Boiler generates overpressure	Boiler overheats. Safety valve fails. Expansion vessel fails in closed system.	Close air supply, watch water temperature in the boiler. Check and, if needed, replace safety valve. Check expansion vessel.

### 8. Boiler disposal

Dispose the boiler after expiration of its service life or if it is uninstalled due to other reasons. Boiler is constructed from various materials, so:

- Bring electric appliances, if present, to electric appliances recycling organization;
- Metal parts go to metal scrap;
- Remaining materials go to landfill or waste storage sites.

*Note. Disposal actions shall be in line with laws and rules of user's country.*

### 9. Safety requirements

#### The following is prohibited:

- To operate boiler without having filled heating system with water. Water in the heating system has to be protected from freezing;
- To connect boiler into closed system without safety valve, which prevents the system from exceeding pressure by more than 0,15 MPa (1,5 kgf/cm<sup>2</sup>);
- To close supply or return water line valves when boiler is in operation;
- To dry fuel or other easily combustible materials near or on the boiler;
- To fire the boiler with the help of easily combustible fluids (petrol, kerosene etc.);
- To operate boiler with open doors or covers;
- To pour non-extinguished coal and ash near living or auxiliary buildings;
- To entrust boiler maintenance to minors or non-trained persons;
- To operate boiler without grounding the case;
- To touch electric installation of the boiler.

Boilers are stored in dry premises, without presence of chemically active substance gases.

*Note. After unpacking the boiler, use its wooden pallet as fuel for the boiler, dispose polythene film to waste disposal company.*

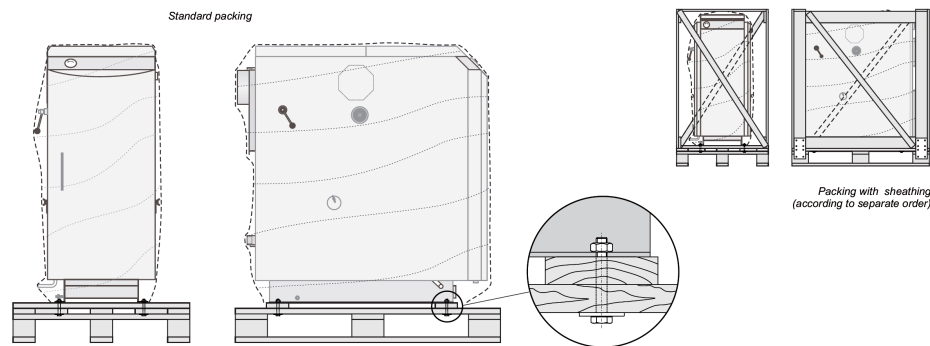

Fig.2a. Boiler packing for transportation.

### 6. Boiler installation

Boiler shall be installed in the premises meeting requirements of BPST Nr.64/2005-02-18; STR 2.01.01(2):1999; STR 2.01.01(6):1999 and STR 2.09.02:2005 as well as according to the solid fuel heater installation in buildings rules ST 8860237.02:1998, or according to relevant requirements of the installation country.

We recommend to install smoke exhaust hood above the boiler. Boiler is to be installed upright or leant forward by no more than 1°.

Premises have to have ventilation, assured fresh air inflow.

Boiler is not allowed to install in living rooms or corridors.

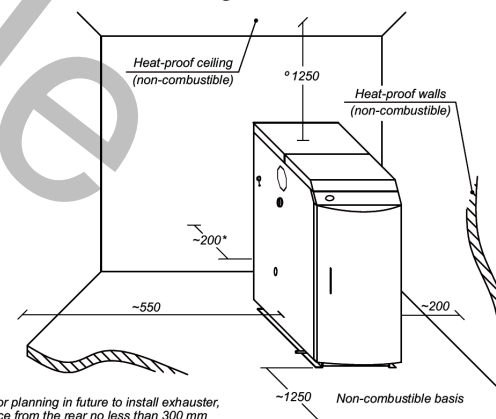

Fig. 2b. Recommended distances to non-combustible partitions

If installing this boiler outside Lithuania, it is necessary to observe all local rules based upon European and national standards.

Before connecting boiler to heating system and chimney, take into consideration the fact that during operation it will have to be cleaned, adjusted etc.

For boiler maintenance as well for fire prevention necessary minimum distances to walls and ceiling are given in fig. 2.

**Note.** Boilers are manufactured in the right positioning option, but user, for own convenience, can reinstall direction of opening the front decorative door (27) and firing valve handle (6) into the opposite side of the boiler. Place of installation of electric heating elements (3), cooling coil (4) and exhauster control panel is provided on the both sides of the boiler.

### 6.1. Fire prevention requirements:

- Put boiler onto non-combustible base;
- If boiler is connected to chimney through metal pipes, they have to be made of no thinner than 1,5 mm metal sheet and coated with heat insulation material.

**Attention!** If chimney draught is too strong, using chips, slivers, hards or other powdery materials as fuel, during its loading or after fuel burns out and its remains are shaken, sparks can flow out of the chimney.

If for roof or building constructions easily-combustible materials are used, or other similar design buildings, building materials, fuel etc. are located closer than 20 m away from the chimney, use of fuel of mentioned kinds is strictly prohibited!

### 6.2. Requirements for chimney

Options for chimney construction and boiler connection to chimney are shown in fig. 3.

#### Requirements:

- Chimney draught has to be no less than it is specified in the main technical specification table (see page 3);
- Chimney hole has to be no less than 120 x 250 mm in cross-section;
- Boiler needs separate chimney hole. Nothing else can be connected into the same hole;
- If chimney is connected with extra elbow, it has to have no less diameter than the cross-section of smoke escaping from boiler hole, with bending radii no less than 100 mm;
- Pipe between boiler flue pipe and chimney has to be no longer than 1,5 m and has to go up towards chimney, providing the possibility for its cleaning;
- Gaps at butting and entrance into chimney places have to be excellently sealed;

#### It is necessary to know that:

- Smoke, after getting into chimney from boiler flue pipe, continues cooling, steam contained in the smoke condense by settling on chimney walls, especially in unheated loft and external part of the chimney;

## 7.6. Boiler cleaning

Ash, accumulated under the firegrate may prevent air supply to the combustion chamber. So, no rarely than every second firing (every second day), remove ash from the ash box and scoop remaining ash from ashtray.

In order to assure efficient boiler operation, it is necessary to periodically clean sooth from internal surfaces of the boiler. Intervals between cleanings depend on fuel quality (especially moisture), burning intensity, chimney draught and other circumstances. It is recommended to clean boiler heat exchanger and combustion chamber when sooth layer is up to 3 mm thick, but no rarely than 2 - 3 times per month. For cleaning take of service cover (5) and thoroughly, with the help of scraper and brush, clean internal surfaces of the boiler. Remove ash and sooth after having unscrewed bottom cleaning cover (21).

In order to remove hardened scale, it is recommended to use chemical cleaners (Swedish „Fauch 300“ or similar).

It is recommended to clean chimney no rarely than every year and necessarily before start of the heating season.

**Attention!** We recommend to remove exhauster before cleaning the boiler in order it was easier to clean the flue pipe and to clean exhauster's impeller.

**Note.** During first firing of the boiler or after a long period of non-firing, chimney can block smoke. In this situation, when firing the boiler, open chimney or boiler chimney connection cleaning door and through it carefully insert lit crumpled paper. Close door after paper burns out. Draught should improve.

## 7.7. Risk analysis and its elimination methods

Safety valve and expansion vessel serve as protection from overpressure in the boiler.

### Don't overheat (boil) water in the boiler.

Water overheating may be caused by: too intense combustion, water level drop or circulation absence in the system.

Fault	Reasons	What to do
Boiler overheats	Too intense combustion. Electric power loss (for systems with forced circulation).	Close air supply, observe water temperature in the boiler. After temperate drops, return to normal combustion mode.
Electric power loss		Call qualified specialist. In winter, when there is no electric power for a longer time and frost risk, discharge water from the system.

chemically aggressive acids, under effect of which boiler service life can be reduced significantly. In order to ensure whether the boiler is tight, burn it intensely for 1-2 hrs, then observe for growing condensate volume. If condensate does not grow in volume, boiler is tight.

In order to ensure whether the boiler is tight, burn it intensely for several hours, then stop burning and observe for growing condensate volume. If condensate does not grow in volume, boiler is tight.

**Attention!** If boiler is operated incorrectly, fuel is unsuitable, low chimney draught, valves installed in the boiler can get stuck, so during the heating season move the valves: open and close several times all the valves installed in the boiler.

### 7.3. Draught regulator adjustment

**Attention!** Draught regulator (28) (see fig. 1) is supplied screwed into the boiler but unsealed, it has to be sealed (see par. 6.5).

After boiler reaches desirable temperature (70±90°C), comparing with the readings of thermal pressure gauge (30) installed in the boiler, set regulator at similar temperature.

**Note.** Regulator's dial misalignment with readings of thermal pressure gauge is possible.

Reduce chain so that primary air supply valves (23) were closed or the gap was no more than 2 mm. Set desired temperature by turning regulator knob to relevant position. If exhauster (11) is used, set its temperature in the same way as for draught regulator (28).

### 7.4. Chimney exhauster control

More about exhauster **DM-01** control read in „Exhauster control manual“.

### 7.5. Boiler extinguishing

During usual operation, boiler is self-extinguishing when fuel charge completely burns out. If boiler has to be extinguished in the forced way, firstly, remove fuel from hearth. Throw burning fuel into a vessel with water – this will reduce smoke in the premises. During forced extinguishing, open roods or windows to assure good ventilation of the premises.

**Attention!** It is prohibited to pour water onto burning fuel in the hearth.

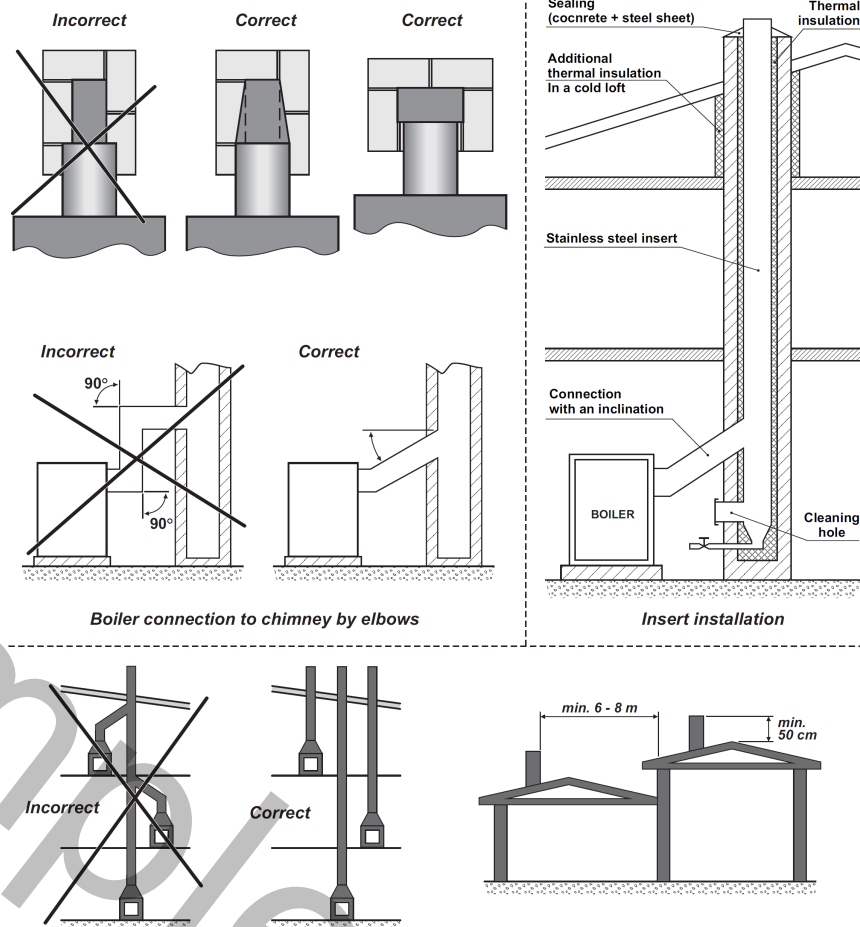

Fig.3.

- Acids of the condensate and heat-cold erosion can disintegrate chimney in a couple of years;
- Uncontrolled sooth in the chimney in some time can get on fire and, if chimney is in bad order or roofing is easily combustible, cause fire.

**We recommend:**

- To install stainless steel insert in the chimney. Orderly installed insert protects chimney from condensate effect and improves draught;
- Insert has not to reduce chimney hole cross-section significantly;
- Parts of the insert have to be sealed together (not by soldering);

- Install condensate collector in the bottom;
- To fill the gap of chimney between insert and chimney walls, at least in the external part of the chimney with non-combustible heat insulation material. Seal the gap on the top right with plaster and trim with tin with inclination from the hole towards chimney edge;
- Winterize chimney in cold loft with non-combustible heat insulation material;
- If inside of the chimney gets on fire, close air supply to the boiler and call firemen;
- In the chimney joint, in the comfortable place, make holes for periodic (once a month) sooth cleaning;
- It is recommended to have chimney examined by qualified chimney maintenance specialist once a year.

### 6.3. Connection to heating system

#### Requirements for connection:

- Boiler has to be connected to heating system in accordance with the project prepared by thermal technique specialists or the works can be performed independently by highly qualified plumber-welder, well experienced and familiarized with boiler design and this manual;
- If in the system pipes there are installed valves, disconnecting the boiler from heating system, they must be fully open. In order to avoid mishap due to negligence, after opening of the valves it is advisable to remove their handles;
- Heating system can be of open or closed type. In this case instead of pressure expansion vessel expansion reservoir can be correctly installed;
- In order to avoid condensate formation, which may reduce service life of the boiler significantly, install in the heating system 4-way or 3-way automatic mixing valves, (see recommended diagrams fig. 4a - 4d), in order to maintain no less than 60°C return water temperature;
- It is necessary to install into the system safety valve, which does not permit exceeding 0,15 MPa (1,5 kgf/cm<sup>2</sup>) working pressure in the heating system. Check valve operation every time when firing the boiler, by turning valve handle;
- Boiler can be connected into heating system (with expansion reservoir which is also safety valve backuping device protecting from overpressure), with working pressure no more than 0,15 MPa (1,5 kgf/cm<sup>2</sup>);
- It is recommended to have boiler examined by qualified boiler maintenance specialist once a year;
- Water discharge pipe is used to discharge water from the system and boiler in the case there is system frosting risk.

Recommended boiler connection diagram options Fig. 4a – 4d

#### **To fill boiler with fuel:**

- Open firing valve (6);
- Open door (22) and verify that ash does not block firegrate holes (21) for air could enter hearth (27). If needed, move bottom fuel layer with poker;
- Close the door (22);
- Turn draught regulator handle(1) to close primary air supply valves in the door (23);
- Open fuel loading door (29), after 15...20 seconds (for opening time: keep opened observing for there is no more smoke in the chamber) fully open the door and load hearth with fuel;
- close tightly the fuel loading door and valves;
- with the means of draught regulator (28) open primary air valves (24).  
We recommend to refill fuel only when the last charge has fully burned out; refilling on non-fully burned out charge is possible only in the case of necessity when there is no other option.

Combustion process control without measuring devices is done by monitoring colour of the smoke going out of the chimney. If combustion process is good, smoke is thin, grey. If smoke is thick and dark, fuel is not fully burn, secondary air is insufficient. In such case open secondary air valves more. secondary air volume is established depending on fuel type and fuel moisture. Combustion quality is checked when water temperature is  $\geq 80^{\circ}\text{C}$ . It is advisable for secondary air adjustment to call a specialist with gas analyser; this is expedient if you have large volume of good quality homogenous fuel..

When fuel burns, ash remains, it covers firegrate; combustion intensity and boiler efficiency drops. Due to this reason fuel has to be poked. Burning coal is poked with poker through gaps if inner door or by moving firegrate with the help of pedal. Large volume of generated ash prevents primary air from entering, so ash has to be removed timely.

Avoid opening fuel loading door during intense combustion (2 and 29).

Boiler combustion needs much air, so enough volume of air has to enter into the premises where boiler is installed.

Recommended consumed fuel moisture is no more than 15-22 %.

**Note.** When boiler is started to operate, during firing, on internal boiler walls, when there is no sooth layer yet, when firewood burns, water condensate forms, which can look like the boiler is not tight and leaks water. Water steam condensate disappears when water temperature in the boiler raises up to 70-80°C with the help of 4-way distributor. It is recommended to maintain water temperature in the boiler as high as possible. If return water temperature is less than 60°C, water steam condenses on internal surfaces of the boiler, which combine with combustion products and form

### 7. Boiler operation

Boiler can be operated by adult persons well familiarized with boiler construction and this technical certificate.

**Attention!** When boiler is fired with damp fuel (firewood or chips), formed condensate combines with combustible gases resulting in acids, which reduce service life of the boiler significantly. Besides that, this is inefficient, because given efficiency rate cannot be reached, so much more firewood is consumed.

It is prohibited to fire the boiler with fine wood waste, because explosion risk or sparking from chimney is possible.

#### 7.1. System preparation for heating

Before firing the boiler, it is necessary to verify that heating system is filled with thermal water and de-aerated; it is recommended to fill with de-salted, soft or at least rain water. If prepared soft water is used in the system, boiler case will serve longer. It is also necessary to verify that the valves disconnecting boiler from the system are open.

#### 7.2. Boiler firing (see fig.1)

When firing the boiler for the first time, also for long period of non-operation (after summer season), it is necessary to heat up the heat-proof concrete parts for the moisture contained inside, turning into steam, did not disintegrate such parts. Put into the hearth, onto firegrate (21) small quantity of fine firewood and, after opening firing valve (6) fire them. Fuel volume must be such that it burned within 20 - 30 min. Repeat the process after 2 hours. Repeat this cycle 3 times.

Before firing the boiler, open firing valve (6), through door (22 and 24) put on firegrate (21) fine-cut dry firewood or slivers and fire. Secondary air hole valves (14) have to be closed. Valves are regulated when temperature in the boiler reaches 60°C.

After the fuel combusts, firing charge burns out, fill loading chamber with fuel (*how to fill: see below*), close firing valve (6).

Fine chopped firewood burns more efficiently and raise boiler power.

Load firewood into loading chamber loose, for while burning they could fall down to the bottom of the chamber.

If coal is to be used, take 5 - 10 kg firewood and top with 10 cm coal. Coal is to be poured layer by layer in a number of times, depending on fuel quality and desirable heat volume.

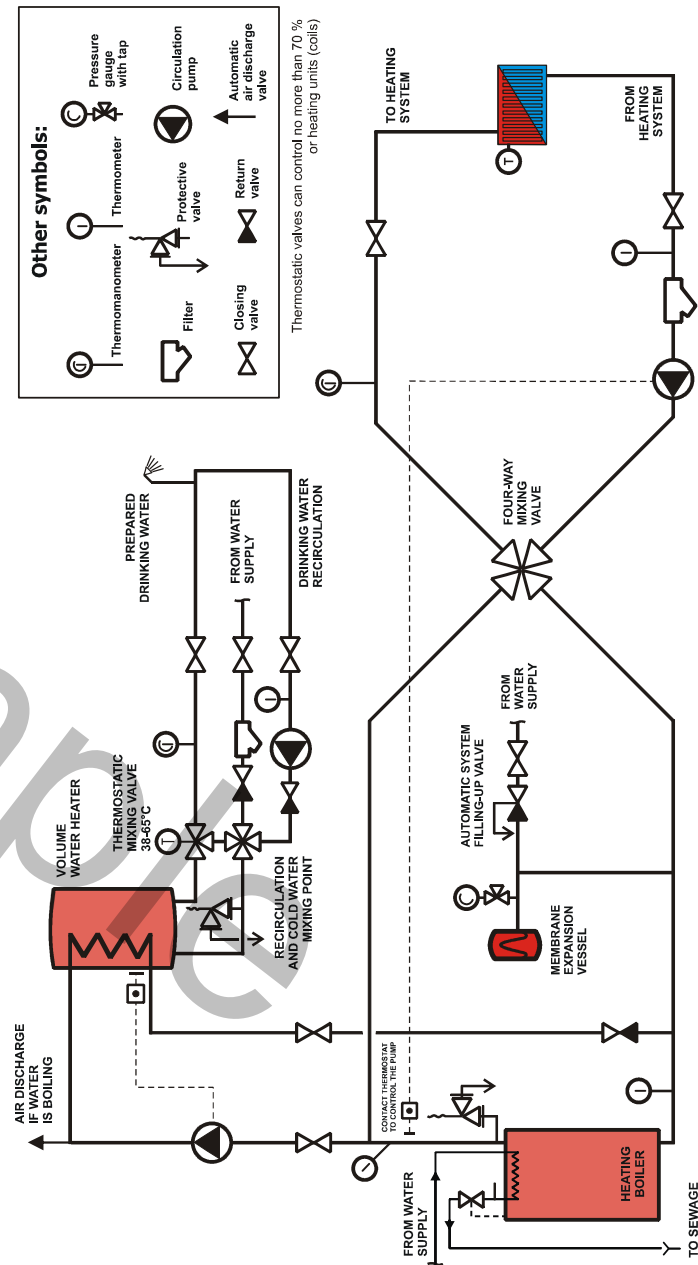

Fig. 4a  
Recommended connection diagram (closed type) using a four way mixing valve, boiler and expansion pressure vessel with membrane. Boiler has a cooling coil installed.

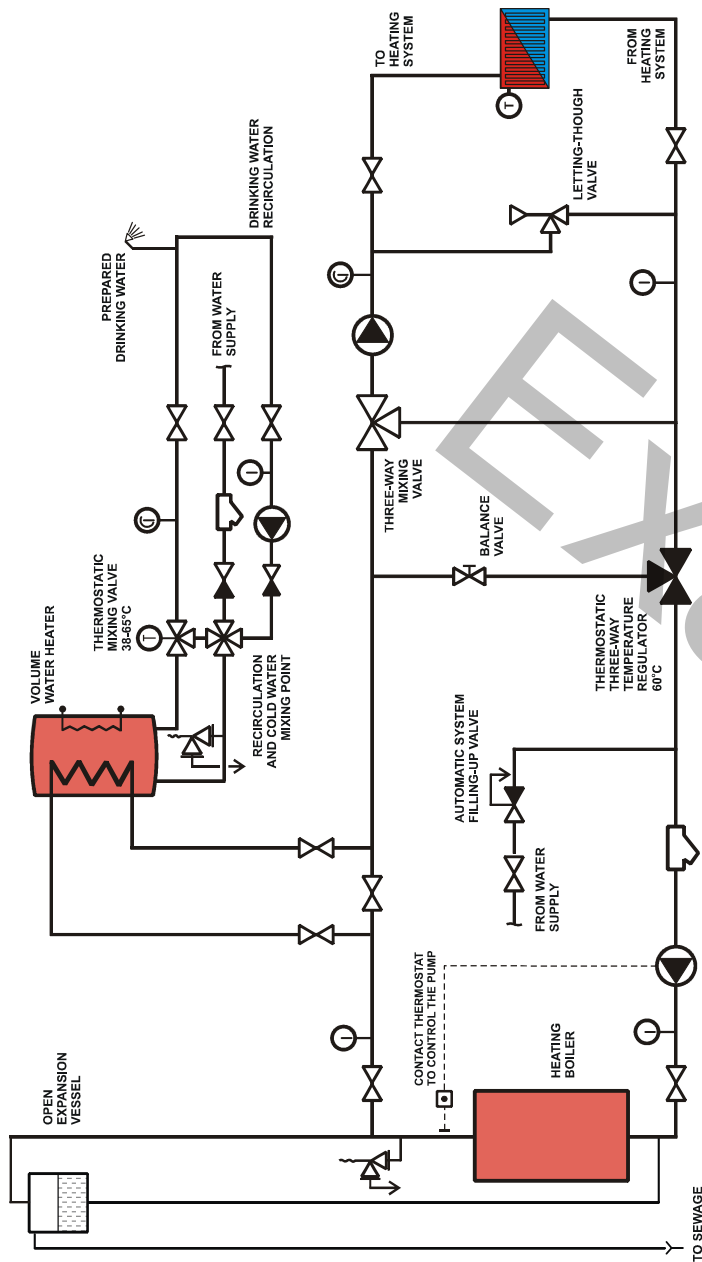

Fig. 4b  
Recommended connection diagram (open type) using three way thermostatic valves, boiler and open expansion tank.

heating system circulation pumps) it is necessary to have extra water supply to the cooling system.

**Attention ! Emergency cooling coil cannot be used for hot water preparation.**

**Note.** For the boilers, operated in open expansion system, it is not necessary to install the device for heat surplus dissipation in the boiler, because heat surplus is dissipated in the form of steam through open expansion vessel. Recommended connection diagrams are given in fig. 4b, 4c.

### 6.7. Requirements for boiler electric part connection

If electric heating elements are installed for the boiler:

- Use only certified heating elements;
- It is recommended to install electric heating elements into the boiler in the case when the boiler is connected to heating system under diagram shown in fig. 4a;
- Electric part connection works on the boiler can be performed by the person having electrician's qualification and permission – licence for execution of installation works;
- Installation works have to be carried out in accordance with the prepared project, (taking into consideration existing general input power).

Recommended electric heating elements connection diagram see fig. 7.

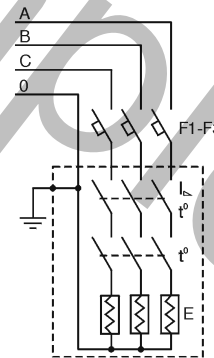

Pos.	Description	Q-ty	
F1-F3	Automatic switch	3	16A
E	Heating element (fastening thread G2B L=400)	1	3x1,5 kW 3x2 kW

fig.7.

Recommended electric heating elements connection diagram

### 6.8. Connection of boiler's exhauster

More about connection of exhauster **DM-01** to the boiler read in Exhauster Control Manual.



**disturbed in the heating system, in order not to exceed the max boiler water temperature.**

For boiler protection from overheating, it is possible to install in its case the safety cooling coil. When boiler heats over 95°C, temperature valve opens and cold water flowing from water supply through the coil cools the boiler. The cooling water is then directed to sewage through pipes no thinner than those installed on exit from the coil (water has to flow freely to sewage).

Recommended cooling system connection is shown in the principal diagrams of the boilerhouse *fig. 4a, 4d*.

Cover tightening scheme. Screw nuts gradually, in specified sequence

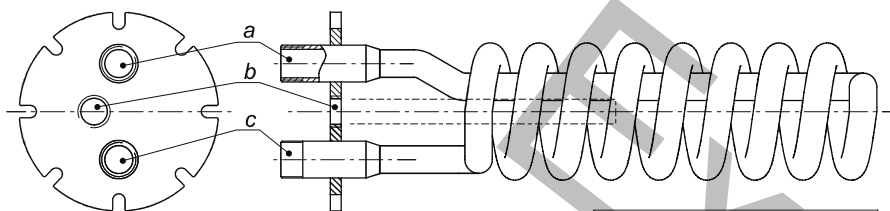
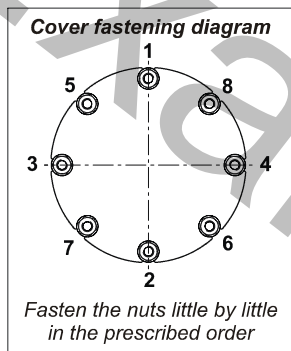

Fig. 6.

- a) cooling water discharge branch (G 3/4)\*
  - b) temperature sensor screwing socket (G 1/2)
  - c) cooling water supply branch (G 3/4)\*
- \* a and c connections can be inter-changed

During cooling coil installation:

- After unscrewing the screws, take cover from trimming shield (or brake perforation away);
- After unscrewing nuts, take the blind away;
- Replace sealing ring;
- Insert and screw in cooling coil (according to directions in the figure).



Temperature valve is connected to the cooling coil (see recommended boiler house connection layouts). Temperature valve has to be connected with no less than 3/4 inch pipes, temperature sensor of the valve is inserted into socket „b“ (see fig.6). Temperature valve used shall have the following parameters:

Min water temperature	10 °C;
Opening temperature	97 ± 2°;
Max water temperature	110 °C;
Max water debit	6,5 m <sup>3</sup> /h;
Max water pressure	10 bar.

If electric power supply is interrupted in the house with local water supply system (water is supplied by hydrophore) boiler overheat can occur (stopped

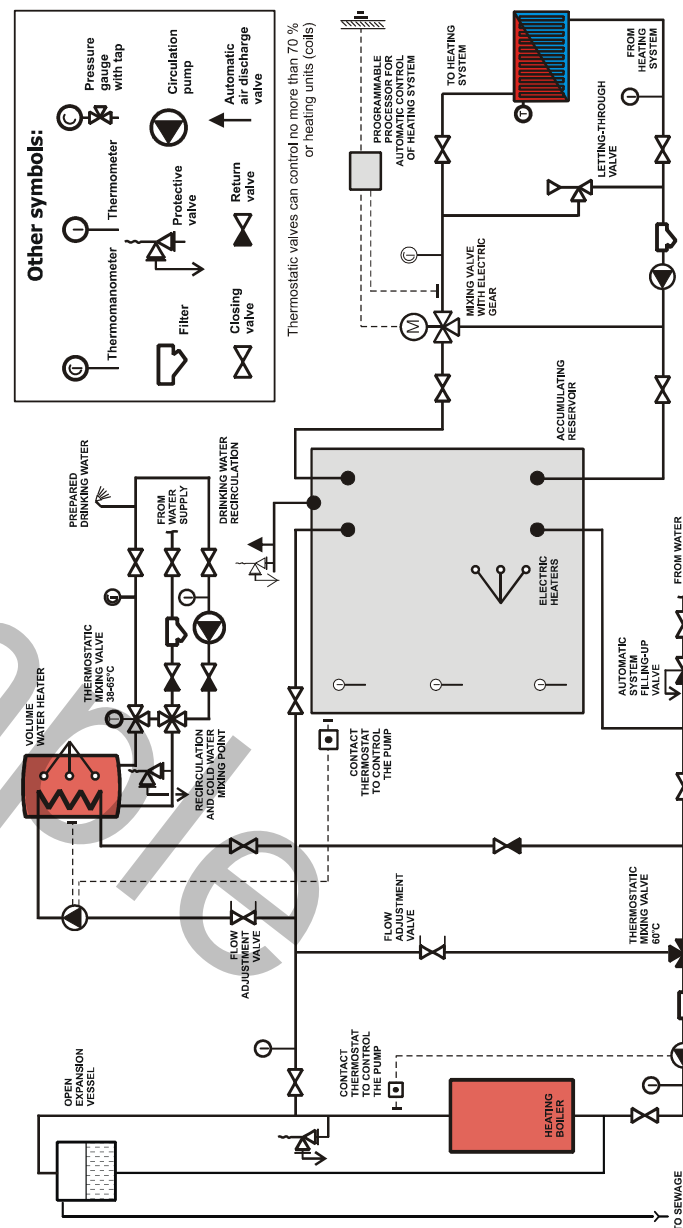

Fig. 4c  
Recommended connection diagram (open type) using three way thermostatic valves, accumulation tank and open expansion tank.

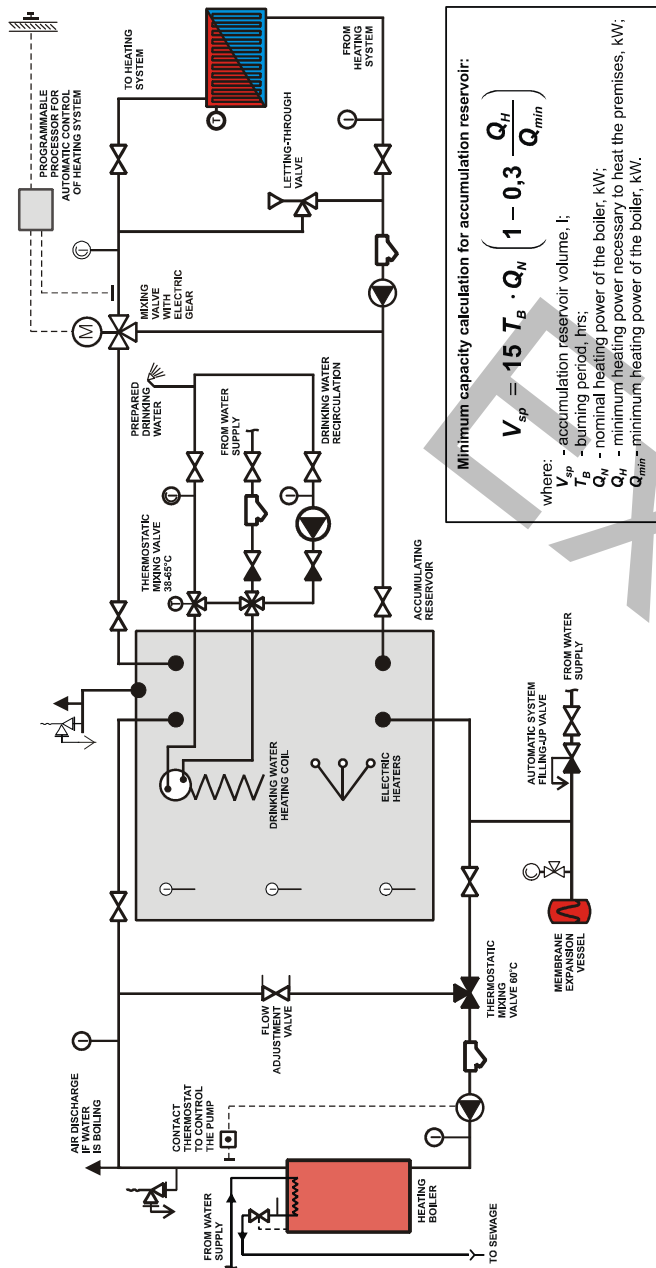

Fig. 4d Recommended connection diagram (closed type) using three way thermostatic valves with accumulation tank, boiler and expansion pressure vessel with membrane. Boiler has a cooling coil installed.

If boiler operates at the power less than the nominal power specified in the technical specifications, efficiency of the boiler reduces, environmental indices become worse. Therefore it is recommended to use boiler connection diagrams with accumulation capacities (see fig. 4c, 4d). Minimum volume of accumulation capacity is calculated according to the formula given at fig. 4d.

#### 6.4. Burning chamber assembly

Boilers are supplied fully assembled, but after completion of all boiler installation works it is necessary to check whether heat-proof concrete bricks are put in correctly (18) (see. fig.1) in the burning chamber (13). If bricks are out of their original positions, return them back to correct places. If the bricks are supplied separately or if you want to replace the worn bricks, do this in the following sequence:

Through front door (22 and 24) into secondary combustion chamber (13) insert the side and the central bricks (D) (see fig.5). Place rear bricks (C) and bottom bricks (B) into the spaces. Lastly, put frontal bricks (A) onto the side and the central brick edges (recess down, towards inside of combustion chamber).

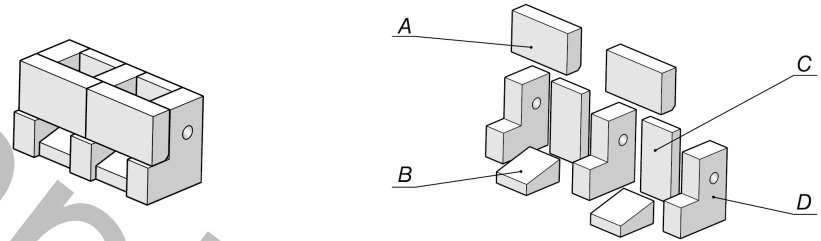

Fig. 5 Firestone brick combustion chamber construction.

#### 6.5. Inserting the draught regulator

**Attention!** Draught adjuster (28) (see fig.1) is supplied screwed into the boiler but not sealed.

Draught regulator (hereinafter referred to as regulator) is screwed in, for sealing using oakum or sealing tape. Connect the chain with primary air supply valves (24) (see also chapter 7.3).

#### 6.6. Connection of cooling system for boiler

According to the requirements of LST EN 303-5 standard par. 4.1.5.11.3, for boiler operation it is necessary to install the devices used for dissemination of heat excess, is for some reasons normal heat take-away is